

# A Photonic QPSK Modulator Aimed at Space Applications

J. Panasiewicz<sup>1,2</sup>, D. M. S. Morais<sup>2</sup>, and G. M. Pacheco<sup>2</sup>

<sup>1</sup>National Institute for Space Research, Brazil

<sup>2</sup>Aeronautics Technical Institute, Brazil

**Abstract**— This paper addresses the subject of the satellite payload signal transmission and the digital-microwave link. Usually, the carrier modulation data transmitter (DT) employs in-phase (I) and quadrature-phase (Q) processing to achieve phase shift keying (M-PSK). Typically, this I/Q processing is obtained by multiplying a low-frequency reference signal. Such systems usually have many stages of multipliers, amplifiers and filters. As a result the microwave transmitter is complicated, bulky and costly. The results presented are based on a photonic circuit that achieves QPSK modulation directly at the microwave frequency carrier. The QPSK modulation was performed using a carrier frequency of 2 GHz and 2 Mbps I/Q signal from a pattern generator using a photonic circuit with a pair of Mach-Zehnder optical modulators arranged in a parallel configuration. The source of the photonic circuit is a DFB diode laser with a wavelength equal to 1550 nm. The modulated optical signal direct detection comes from an InGaAs photo detector. The optical modulator circuit output can be directly connected to the high power amplifier (HPA) and the transmission antenna. The resulting system enables one to achieve a microwave data transmitter with a reduced mass and volume, further lowering power consumption. These achievements are very important for spacecraft engineering teams during the conception of the satellite payloads when starting a new satellite project. Gamma radiation and thermal effects of the space environment are also discussed.

## 1. INTRODUCTION

Microwave photonic technology has attracted significant interest in many applications, such as wireless communications, RF up-conversion, optical oscillator, etc. [1]. Photonic technologies have many advantages over traditional electrical systems, such as high data rates, low weight and size. They are immune and do not induce electromagnetic interference (EMI), as well as being galvanically isolated and transparent to any modulation format.

In satellite engineering these advantages are desired due to the special economic and technical aspects related to building and operating satellite [2].

In this manner, much work has been directed towards the use of photonic technologies for spacecraft [3]. Since 2002 the European Space Agency (ESA) has been conducting a program of Research and Development to study the application of photonics in spacecraft [2]. As an example, it is possible to point out the on board optical fiber distribution of RF signal inside a satellite [4].

The Low Earth Orbit (LEO) satellite operates at altitudes from 160 to 2500 km and with proper inclination, has a restricted operation period from 8 to 10 minutes from a fixed location on earth, because the satellite is not a fixed location in the sky [5]. The satellites of National Institute for Space Research (INPE) are used to collect data from remote stations and image the Earth for deforestation control. The communication link of such satellites operates in the S and X bands for tracking, telemetry, command (TT&C) and image transmission. In the X band, the link operates using QPSK modulation. This technique is the preferred form of digital modulation due to the relatively simple implementation, high powered efficiency, the relatively narrow main lobe width and half bandwidth when compared to the BPSK modulation [6].

For the China-Brazil Earth Resources Satellite (CBERS) program, a QPSK transmitter in X band and data rate of 68 Mbps [7] that utilizes modular components with microwave technology was developed at INPE. The I/Q processing is obtained by multiplying a low-frequency reference signal and to reach the X band such a system has stages of multipliers, amplifiers and filters. Due to the many subsystems the microwave data transmitter is complicated, bulky and costly.

Thus, taking advantage of the advent of photonic technology and its use in space environment, we investigate a QPSK modulator using an external modulation technique and direct detection IM/DD. Utilizing photonic technology it is possible to eliminate spurious emissions and filtering requirements associated with the multiplication of the frequency in the electric domain, resulting in a potential increase of the carrier modulation bandwidth [8]. This article shows the first results and discusses its use in space environment.

## 2. SYSTEM DESCRIPTION

Actually, the photonic vector modulator generation employs different techniques. Usually it is 1 — a parallel structure [9], where two Mach-Zehnder intensity modulator, MZIM, are embedded in a main modulator dual-parallel MZIM (DPMZIM). A phase shift of  $\pi/2$  is introduced in one arm making the optical signals orthogonal to each other; 2 — serial or cascade structure [10], where the first MZIM modulates the in-phase signal, I, and the second one modulates the quadrature signal, Q. These two modulators are connected in cascade; 3 — a dual-drive Mach-Zehnder (MZDD) [11], where the I and Q signals are connected to each port.

The system implemented in this study is based on the parallel configuration mentioned above. Instead of an embedded modulator, two separated MZIMs connected by an optical splitter were used. A single CW laser was used. Previous authors used two separated laser source [8]. The block diagram is shown in Figure 1. The microwave signal is split by a 90 degree hybrid to generate the  $\cos(\omega t)$  and  $\sin(\omega t)$  components. The binary data signal is provided by a pseudo random bit sequence (PRBS) separated into two data channels I and Q. The system configuration is similar to a photonic phase shifter for phased array antenna [12].

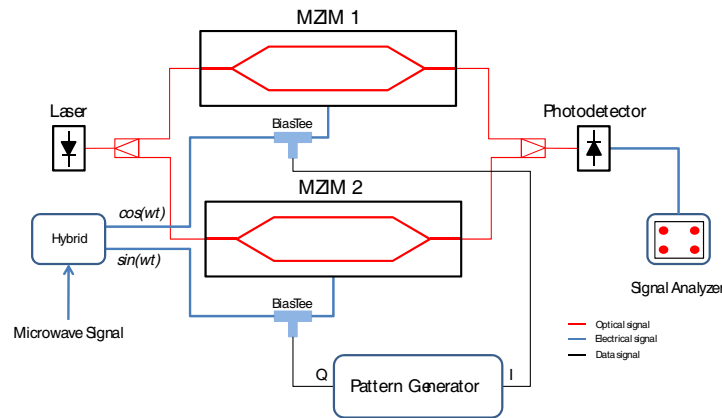

Figure 1: System block diagram.

The MZIM used a chirp free (push-pull modulators) [13]. The output optical field of each MZIM can be expressed as:

$$E_{out1}(t) = \frac{E_0}{2} \cos \left( \pi \left[ \frac{Vd}{V\pi} Data(t) + \frac{Vm}{V\pi} \cos(w_r f t) \right] \right) \cos(w_0 t) \quad (1)$$

$$E_{out2}(t) = \frac{E_0}{2} \cos \left( \pi \left[ \frac{Vd}{V\pi} Data(t) + \frac{Vm}{V\pi} \sin(w_r f t) \right] \right) \cos(w_0 t) \quad (2)$$

where  $Data(t)$  is the transmitted data “0” and “1” and  $Vd$  is the amplitude of NRZ signal of  $Data(t)$ ,  $V\pi$  is the MZIM half-wave voltage,  $Vm$  and  $w_r f$  are the amplitude and the angular frequency of the electrical driving signal while  $E_0$  and  $w_0$  are the amplitude and angular frequency of the optical carrier.

From Equations (1) and (2), it can be noted that switching the amplitude data signal between the values of  $-V\pi/4$  and  $3V\pi/4$  the modulation BPSK is performed on each MZIM. As the transfer function of an MZIM is a periodic function, the phase of the optical field changes its sign but it is equal in magnitude, i.e., two equal intensity points of the transmission function separated by the modulator bias voltage have opposite optical phase, nearing perfect  $180^\circ$  [8, 14].

The optical signals of the each MZIM output when combined using a 50/50 optical coupler and detected by a photodetector results in a QPSK modulated microwave carrier. As the output of the photodetector had an impedance of 50 ohms, the signal can be connected directly in a high power amplifier (HPA) and after in a digital filter.

## 3. EXPERIMENTAL RESULTS

In order to verify the proposed scheme, a 2 GHz microwave carrier was applied to both MZIM by a bias tee. The MZIM are a Lucent 2623NA  $LiNbO_3$  devices with  $V\pi = 3.2V$ . They are driven by

a DFB laser diode with wavelength of 1550 nm and power of 16 mW. The PRBS was provided by an Agilent 81130A with a code rate equal to 1 Mbps and length of  $2^{15} - 1$ . The signal was injected into the bias tee DC connector of each MZIM. The photodetector used was a Thorlabs InGaAs 5 GHz photodiode.

Figure 2(a) show the constellation diagram and transmission statistics measured with the Agilent N9020A Signal Analyzer for BPSK modulation at 1 Mbps on one channel. Figure 2(b) show the spectrum of BPSK signal where the main lobe width of 2 MHz correlates exactly to a modulation of 1 Mbps.

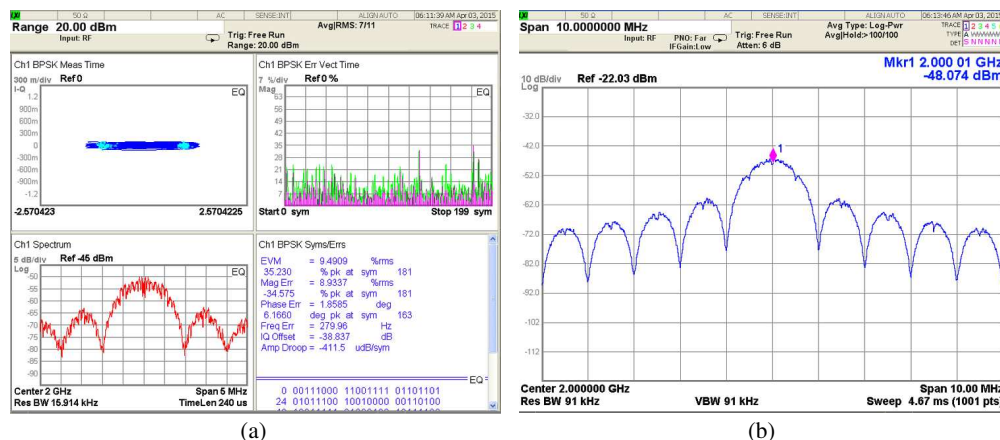

Figure 2: (a) BPSK constellation. (b) BPSK spectrum.

To perform the QPSK modulation, both BPSK channels have to have good performance on EVM. But, one of the MZIM channel had an EVM of 18%. A modulation with 1 Mbps on each channels (I and Q) totalizing one modulation of 2 Mbps was performed. Figures 3(a) and 3(b) show the QPSK constellation and spectrum of the modulation. The width of main lobe is 2 MHz, corresponding to a 2 Mbps QPSK modulation.

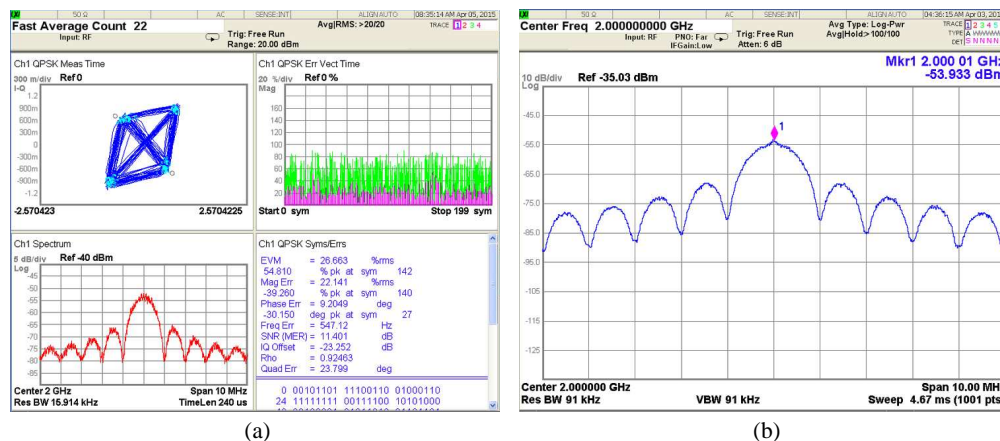

Figure 3: (a) QPSK constellation. (b) QPSK spectrum.

The data rate was incremented from 500 kbps to 2.5 Mbps and was limited by the frequency response of the bias tee. Although the International Telecommunications Union (ITU) assigned X band downlink frequency from 8025 to 8400 MHz, with the bandwidth of 375 MHz by channel [15], no attempt was made to increase the microwave carrier since the photodetector is limited to 5 GHz.

#### 4. SPACE ENVIRONMENTAL

In the conception of a spaceflight mission and consequently in the design of payloads, the space environmental factors should be considered. In LEO, this environment includes many hazards such as UV radiation, ionizing radiation, atomic oxygen, plasma, radiation belts, high vacuum (induces material outgassing), orbital debris, as well as severe temperature cycles [16, 17].

Considering the ionizing radiation, space environment has a low dose rate of  $10^{-4}$  to  $10^2$  rad/s. Although large accumulated doses can be reached as the duration of a mission may last years, total ionizing dose (TID) levels on the order of  $10^5$  rad, can be easily accumulated over the life of a spacecraft mission [18]. Therefore, devices, such as lasers, photodetectors, optical fibers, optical amplifiers, Mach Zehnder modulators need to be qualified considering performance against the requirements of a spacecraft mission. A theoretical study was carried out regarding the performance of eletro-optic modulators under neutrons irradiation [19] and provided good results.

## 5. CONCLUSION

This study presents a direct carrier modulation with the use of a photonic vector modulator suitable for radio digital communications of LEO satellites. A set of two Mach-Zehnder optical modulators in parallel and a common laser source and unique photodetector were used. Operating at 1550 nm and with control voltage between  $-0.85$  V to  $2.5$  V the setup was tested with a pseudo random signal sequence of data.

Digital modulation, BPSK and QPSK were experimentally demonstrated with a carrier frequency of 2 GHz and a data rate limited to the 2.5 Mbps. The results suggest some MZIM modulators criteria selection and enable us to consider the construction of a higher frequency system for real satellite data transmission tests operating at around 8 GHz.

## ACKNOWLEDGMENT

The authors acknowledge MSc. Luciano Barros Cardoso da Silva for discussion about BPSK and QPSK modulation. The authors also wish to acknowledge Dr. Lúcio Baptista Trannin Cividanes and Dr. Mario Luiz Selingardi for providing electrical test equipment to perform the measurements.

## REFERENCES

1. Yao, J. P. "A tutorial on microwave photonics," *IEEE Photon. Soc. Newsletter*, Vol. 26, No. 2, 412, 2012.
2. Karafolas, N., J. P. Armengol, and I. Mckenzie, "Introducing photonics in spacecraft engineering: ESA's strategic approach," *Aerospace Conference*, 1–15, IEEE, 2009.
3. Ressia, J. H. and J. L. Peck, "Fiber optics demonstrated use in space vehicles," *RAST'03. International Conference on. Proceedings of Recent Advances in Space Technologies*, 321–324, IEEE, 2003.
4. Bénazet, B., M. Sotom, M. Maignan, and J. Berthon, "Optical distribution of local oscillators in future telecommunication satellite payloads," *5th International Conference on Space Optics*, Vol. 554, 589–594, 2004,
5. Ippolito, Jr, L. J., *Satellite Communications Systems Engineering: Atmospheric Effects, Satellite Link Design and System Performance*, Vol. 6, John Wiley & Sons, 2008.
6. Bokulic, R. S., C. C. DeBoy, S. W. Enger, J. P. Schneider, and J. K. McDermott, *Spacecraft Subsystems IV Communications and Power. Space Mission Engineering: The New SMAD*, Microcosm Press, 2011.
7. Tosetto, I., L. Cividanes, B. Santos, L. Silva, and R. Araújo, "Transmissor QPSK em Banda X para Aplicação Espacial," *XXV Simpósio Brasileiro de Telecomunicações*, 2007.
8. Jemison, W. D., A. J. Kreuzberger, and E. Funk. "Microwave photonic vector modulator for high-speed wireless digital communications," *IEEE Microwave and Wireless Components Letters*, Vol. 12, No. 4, 125–127, 2002.
9. Jiang, Jr., W., et al., "Photonic vector signal generation employing a novel optical direct-detection in-phase/quadrature-phase upconversion," *Optics Letters*, Vol. 35, No. 23, 4069–4071, 2010.
10. Loayssa, A. and D. Benito, "All-optical implementation of broadband QPSK subcarrier modulator," *Electronics Letters*, Vol. 40, No. 21, 1362–1364, 2004.
11. Binh, L. N., "Generation and transmission of multilevel quadrature amplitude modulation formats using only one optical modulator: MATLAB Simulink simulation models," *Optical Engineering*, Vol. 48, No. 4, 5005, 2009.
12. Coward, J. F., et al., "A photonic integrated-optic RF phase shifter for phased array antenna beam-forming applications," *Journal of lightwave technology*, Vol. 11, No. 12, 2201–2205, 1993.
13. Li, G. L. and P. K. L. Yu, "Optical intensity modulators for digital and analog applications," *Journal of Lightwave Technology*, Vol. 21, No. 9, 2010, 2003.

14. Gnauck, A. H. and P. J. Winzer, "Optical phase-shift-keyed transmission," *Journal of Light-wave Technology*, Vol. 23, No. 1, 115, 2005.
15. International Telecommunication Union (ITU) Handbook EESS, 2011.
16. Teichman, L. A. and B. A. Stein, "NASA/SDIO Space Environmental Effects on Materials Workshop", Part 1. No. NASA-L-16575, "National aeronautics and space administration hampton va langley research center", Hampton Virginia, June 28–July 1, 1988.
17. Tobiska, W. K., *The Space Environment. Space Mission Engineering: The New SMAD*, Microcosm Press, 2011.
18. Maurer, R. H., M. E. Fraeman, M. N. Martin, and D. R. Roth, "Harsh environments: Space radiation environment, effects, and mitigation," *Johns Hopkins APL Technical Digest*, Vol. 28, No. 1, 17, 2008.
19. Rashed, A. N. Z., "Speed performance degradation of electro-optic modulator devices by neutrons irradiations at high temperature effects," *IJCEM International Journal of Computational Engineering & Management*, Vol. 14, No. 1, 1–8, 2011.